

# AC Power Capacitors

Ideal for Power Factor and Harmonic Filter Systems



**Safer, Stronger  
AC Power Capacitors**

# Safer, Stronger AC Power Capacitors

Achieve reliability and long life expectancy for your capacitor system

With over 85 years of experience producing capacitors, plus decades of leadership in the European market for power factor systems, **FRAKO** knows what it takes to produce capacitors that are highly reliable in real world applications for power factor and harmonic filter systems. **FRAKO** developed the LKT -DD60 and -DP60 ranges of dry type capacitors with a combination of safety features and strong ratings to assure satisfactory operation and life expectancy in power factor and harmonic filter systems.

## Self-healing, Segmented Metalized Film

All metalized polypropylene capacitors offer self healing features to extend the life of a capacitor when it has been subjected to transients. When exposed to severe, transients, the dielectric strength of the winding is weakened and a short circuit occurs in the capacitor winding. For severe transients, or strenuous applications, the short circuit may penetrate multiple layers of the capacitor winding, resulting the catastrophic failure of a capacitor.



Self-healing event in typical metalized film

**FRAKO** introduced segmented self-healing metalized film in 2008 to protect against catastrophic failures of capacitors. Segmented film serves to limit the amount of energy available during the self-healing process and will completely isolate the localized short circuit before it can grow to affect multiple layers. The use of segmented film achieves maximum protection against bursting capacitors.

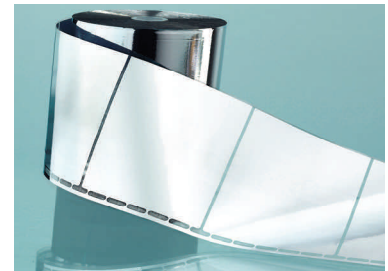

**FRAKO** Segmented, self-healing metalized film

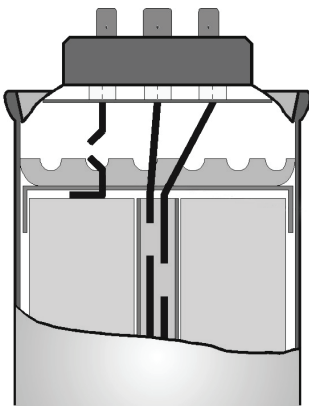

3-phase over-pressure Disconnection

## 3-phase Overpressure Disconnection

Metalized polypropylene capacitors are required to provide an internal method of disconnecting the capacitor in case of excessive internal pressure. Since the requirement is not specific, many 3-phase capacitors disconnect only two phases, which is sufficient to stop current flow. However, this method leaves voltage applied to one winding which may still result in a safety hazard. **FRAKO** capacitors feature an overpressure disconnection method that will disconnect all three phases (windings) in case of excessive internal pressure. This is another technique that **FRAKO** employs to maximize protection against catastrophic failures which may result in bursting capacitors.

# Safer, Stronger AC Power Capacitors

Achieve reliability and long life expectancy for your capacitor system

Power systems today demand a stronger capacitor than in the past. Most electrical power systems have harmonic voltage and current distortion, which will cause higher capacitor currents and raise the internal temperatures within the capacitor system enclosure. **FRAKO** developed the type DD60 and DP60 capacitors with a combination of safety features and strong ratings to assure reliability and long life expectancy within power systems that have current and voltage distortion. These capacitors are uniquely designed for long life in power factor and harmonic filter systems.

## High Ambient Temperature Capability

Inside of electrical enclosures for power factor capacitors or harmonic filters, temperatures may be 10°C to 20°C degrees hotter than the ambient room air. Many capacitors require derating whenever the air temperature around the capacitor exceeds 35°C to 46°C.

**FRAKO** capacitors are rated for continuous use in an ambient temperature of up to 60°C degrees (no derating necessary).

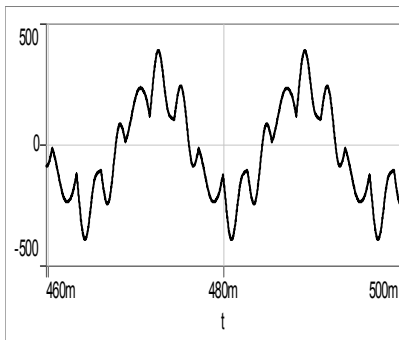
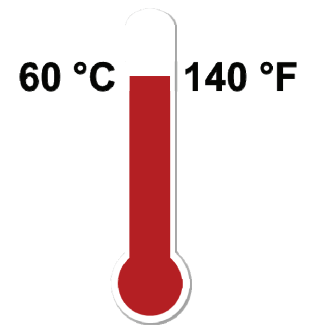

## High Harmonic Current Capability

Whether a capacitor is used in a power factor system or in a harmonic filter, today's capacitor installations are typically subjected to harmonics. System harmonics can increase the capacitor current above its rated capability and will also increase the capacitor internal temperature. This contributes to shortened capacitor life.

**FRAKO** capacitors are designed and rated for high harmonic current and can continuously carry up to 165 % of their nominal capacitor current.

## Secure, Maintenance Free Terminals

Terminals are a common failure point in capacitor systems because over time the typical screw terminals can loosen, resulting in a high resistance connection and ultimate failure of the wiring or terminal.

**FRAKO** -DD60 and -DP60 capacitors are supplied with (factory installed) screwless terminations that secure wiring with a maintenance free, anti-vibration connection. Not only are they easy to wire, but they also maintain terminal pressure for the lifetime of the capacitor.



Suitable for 14 to 6 AWG solid, stranded or fine stranded (CU) copper wires

# LKT 3-phase Dry-Type Capacitors

## Construction Details

**FRAKO** produces AC Power Capacitors using their unique Dry-Type construction to provide high reliability in rigorous applications of power factor and harmonic filter systems. For best capacitor performance and longest life expectancy, **FRAKO** combines optimized winding construction for low internal heating with unique heat removal techniques.

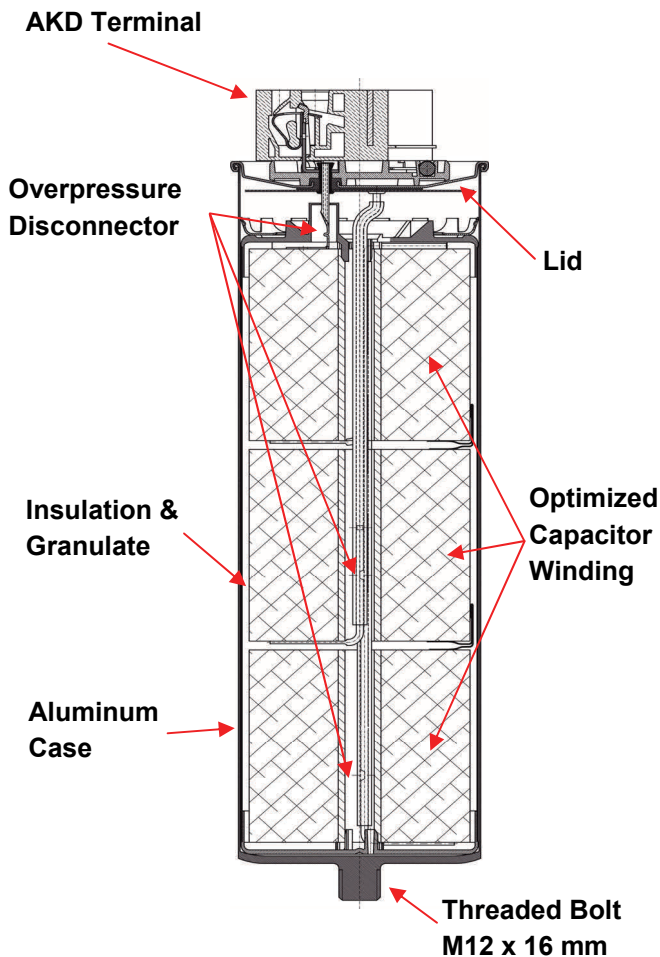

### Optimized Winding Geometry

**FRAKO** produces capacitor windings using relatively short coils with moderate diameters because this coil geometry is known to generate much less internal heat than other winding construction methods.

### Oiled Polypropylene Film

**FRAKO** applies a thin film of vegetable oil to the entire surface of each winding to facilitate heat transfer and to prevent oxidation of the metalized winding surface.

### Absorbent Granulate

**FRAKO** capacitors are filled with dry absorbent granulate to assure the absence of liquid (oil), for heat dissipation and for improved safety by enabling overpressure disconnection to occur at lower internal pressure.

## Standard Features that exceed Industry Standards

- No Leak, Dry-Type Construction
- Factory Installed Discharge Resistors
- Finger-Safe Maintenance Free Terminals
- Uniform Diameter for all Capacitors
- Compact Design
- High Current Capability
- Handles Harmonic Current
- High Temperature Rating
- Triple Safety Features
- Handles High Altitude

# LKT 3-phase Dry-Type Capacitors

## General Specification

Type		LKT ...-DD60	LKT ...-DP60
<b>Safety Features</b>		Self-healing polypropylene film, segmented metallized film 3-phase overpressure disconnecter	
<b>Applicable Standards</b>		UL 810, CSA 22.2 No. 190, IEC/EN 60831-1 and -2	
<b>Agency Approvals</b>			
<b>Rated Voltage</b>	$V_{Nom}$	240, 480 & 600 V	690 & 800 V
<b>Maximum Voltage</b> (continuous)	$V_{Max}$	110 % of Rated Voltage	100 % of Rated Voltage
<b>Rated Frequency</b>	$f_N$	60 Hz , may also be used at 50 Hz	
<b>Tolerance</b> ( $\mu F$ and KVAR)		-0 % / +5 %	
<b>Internal Connection</b>		delta	
<b>Maximum Current</b> (continuous)		165 % x $I_{Nom}$	150 % x $I_{Nom}$
<b>Power Losses</b>		$\leq 0.2$ W / kVAR (dielectric) $\leq 0.5$ W / kVAR (total)	
<b>Discharge</b> (resistors factory installed)		$\leq 50$ V, within 60 seconds discharge	
<b>Max. temporary Overvoltage</b>		110 % $V_{MAX}$ , 8 hours per day 115 % $V_{MAX}$ , 30 minutes per day 120 % $V_{MAX}$ , 5 minutes 130 % $V_{MAX}$ , 1 minute	110 % $V_{Nom}$ , 8 hours per day 115 % $V_{Nom}$ , 30 minutes per day 120 % $V_{Nom}$ , 5 minutes 130 % $V_{Nom}$ , 1 minute
<b>Maximum Inrush Current</b>	$I_S$	228 x $I_{Nom}$	208 x $I_{Nom}$
<b>Routine Voltage Test</b> (Terminal / Terminal)	$V_{TT}$	2.15 x $V_{Max}$ , 2 seconds, plus 1.85 x $V_{Max}$ , 18 seconds	
<b>Routine Voltage Test</b> (Terminal / Case)	$V_{TC}$	$V_{Nom} < 600$ V = 3,900 V, 2 seconds $V_{Nom} \geq 600$ V = 4,300 V, 2 seconds	
<b>Other Routine Tests</b>		Case seal test, capacitance, loss factor and resistance measurement	
<b>Ambient Temperature</b> (continuous)		-40 °C to 60 °C	
<b>Case Temperature</b> (max.)		75 °C	
<b>Storage Temperature</b> (min. /max.)		-40 °C to 85°C	
<b>Humidity</b> (max.)		95 % non-condensating	
<b>Altitude</b> (max.)		4,000 meters above sea level	
<b>Life Expectancy</b>		130,000 hours (at max voltage, current, ambient) with up to 40,000 switchings per year	
<b>Mounting and Fixing</b>		Vertical or horizontal by M12 x 16 mm stud (15 Nm tightening torque)	
<b>Terminals</b>		Screwless pressure connection, 14 to 6 AWG solid or stranded CU wire	

# Product Selection & Technical Data

## Type DD60 Capacitors for 240 V / 60 Hz System Voltage

**FRAKO** type LKT -DD60 240V capacitors are multi-purpose capacitors for use in Power Factor and Harmonic Filter Systems.

Continuous voltage capability of 110% rated voltage makes them suitable for use with or without a series (tuning, de-tuning or filter) reactor.

Permitted operating & overvoltages	
Max. Voltage (continuous)	264 V
8 hours / day	290 V
30 minutes / day	304 V
5 minutes	317 V
1 minute	343 V

### Product Selection Chart

Catalogue No.	Power	Power	Capacitance	Current		ESR	Dimensions	Weight	Part No.
	Q <sub>C</sub>	w/ 7%		I <sub>Nom</sub>	I <sub>Max</sub>				
	[kVAR]	[kVAR]	C <sub>N</sub> Δ	[A]	[A]	at 1 kHz	d x h	[kg]	
			[μF]			[mΩ]	[mm]		

Rated Voltage: 240 V / 60 Hz

LKT 1.0-240-DD60	1.00	1.07	3 x 15.3	2.4	4.0	3 x 3.5	85 x 198	1.20	31-10901
LKT 1.5-240-DD60	1.50	1.61	3 x 23.0	3.6	5.9	3 x 2.3	85 x 198	1.20	31-10902
LKT 2.0-240-DD60	2.00	2.15	3 x 30.7	4.8	7.9	3 x 1.7	85 x 198	1.20	31-10903
LKT 2.5-240-DD60	2.50	2.68	3 x 38.3	6.0	9.9	3 x 1.4	85 x 198	1.20	31-10904
LKT 3.0-240-DD60	3.00	3.22	3 x 46.0	7.2	11.9	3 x 1.2	85 x 198	1.20	31-10905
LKT 4.0-240-DD60	4.00	4.30	3 x 61.4	9.6	15.8	3 x 0.9	85 x 198	1.20	31-10906
LKT 5.0-240-DD60	5.00	5.37	3 x 76.7	12.0	19.8	3 x 0.7	85 x 198	1.20	31-10907
LKT 6.0-240-DD60	6.00	6.45	3 x 92.1	14.4	23.8	3 x 0.6	85 x 198	1.20	31-10908
LKT 7.5-240-DD60	7.50	8.06	3 x 115.0	18.0	29.7	3 x 0.5	85 x 198	1.20	31-10909
LKT 8.33-240-DD60	8.33	8.94	3 x 127.8	20.0	33.0	3 x 0.4	85 x 198	1.20	31-10910
LKT 10.0-240-DD60	10.00	10.75	3 x 153.4	24.0	39.8	3 x 0.3	85 x 198	1.20	31-10911
LKT 11.7-240-DD60	11.70	12.57	3 x 179.0	28.0	46.4	3 x 0.3	85 x 250	1.55	31-10912
LKT 12.5-240-DD60	12.50	13.44	3 x 191.7	30.0	49.7	3 x 0.3	85 x 250	1.55	31-10913
LKT 15.0-240-DD60	15.00	16.12	3 x 230.1	36.0	59.6	3 x 0.2	85 x 250	1.55	31-10914
LKT 16.7-240-DD60	16.70	17.95	3 x 255.7	40.0	66.3	3 x 0.2	85 x 250	1.55	31-10915
LKT 17.5-240-DD60	17.50	18.80	3 x 266.4	42.0	69.1	3 x 0.2	85 x 313	1.90	31-10916
LKT 20.0-240-DD60	20.00	21.50	3 x 306.8	48.0	79.4	3 x 0.2	85 x 313	1.90	31-10917

# Product Selection & Technical Data

## Type DD60 Capacitors for 480 V / 60 Hz System Voltage

**FRAKO** type LKT -DD60 480V capacitors are multi-purpose capacitors for use in Power Factor and Harmonic Filter Systems.

Continuous voltage capability of 110% rated voltage makes them suitable for use with or without a series (tuning, de-tuning or filter) reactor.

Permitted operating & overvoltages	
<b>Max. Voltage</b> (continuous)	528 V
<b>8 hours / day</b>	581 V
<b>30 minutes / day</b>	607 V
<b>5 minutes</b>	634 V
<b>1 minute</b>	686 V

### Product Selection Chart

Catalogue No.	Power	Power	Capacitance	Current		ESR	Dimensions	Weight	Part No.
	Q <sub>C</sub>	w/ 7%		I <sub>Nom</sub>	I <sub>Max</sub>				
	[kVAR]	[kVAR]	C <sub>N</sub> Δ [μF]	[A]	[A]	at 1 kHz [mΩ]	d x h [mm]	[kg]	

Rated Voltage: 480 V / 60 Hz

LKT 1.0-480-DD60	1.00	1.07	3 x 3.8	1.2	2.0	3 x 14.0	85 x 198	1.20	31-10918
LKT 1.5-480-DD60	1.50	1.61	3 x 5.8	1.8	3.0	3 x 9.2	85 x 198	1.20	31-10919
LKT 2.0-480-DD60	2.00	2.15	3 x 7.7	2.4	4.0	3 x 6.9	85 x 198	1.20	31-10920
LKT 2.5-480-DD60	2.50	2.68	3 x 9.6	3.0	5.0	3 x 5.5	85 x 198	1.20	31-10921
LKT 3.0-480-DD60	3.00	3.22	3 x 11.5	3.6	5.9	3 x 4.6	85 x 198	1.20	31-10922
LKT 4.0-480-DD60	4.00	4.30	3 x 15.4	4.8	7.9	3 x 3.4	85 x 198	1.20	31-10923
LKT 5.0-480-DD60	5.00	5.37	3 x 19.2	6.0	9.9	3 x 2.8	85 x 198	1.20	31-10924
LKT 6.0-480-DD60	6.00	6.45	3 x 23.1	7.2	11.9	3 x 2.3	85 x 198	1.20	31-10925
LKT 7.5-480-DD60	7.50	8.06	3 x 28.9	9.0	14.9	3 x 1.8	85 x 198	1.20	31-10926
LKT 9.4-480-DD60	9.40	10.10	3 x 35.9	11.3	18.6	3 x 1.5	85 x 198	1.20	31-10927
LKT 10.0-480-DD60	10.00	10.75	3 x 38.5	12.0	19.8	3 x 1.4	85 x 198	1.20	31-10928
LKT 11.7-480-DD60	11.70	12.57	3 x 44.9	14.0	23.3	3 x 1.2	85 x 250	1.55	31-10929
LKT 12.5-480-DD60	12.50	13.44	3 x 48.1	15.0	24.8	3 x 1.1	85 x 250	1.55	31-10930
LKT 15.0-480-DD60	15.00	16.12	3 x 57.4	18.0	29.7	3 x 0.9	85 x 250	1.55	31-10931
LKT 16.7-480-DD60	16.70	17.95	3 x 64.2	20.0	33.2	3 x 0.8	85 x 250	1.55	31-10932
LKT 17.5-480-DD60	17.50	18.80	3 x 67.0	21.0	34.7	3 x 0.8	85 x 313	1.90	31-10933
LKT 18.8-480-DD60	18.80	20.21	3 x 72.2	22.6	37.3	3 x 0.7	85 x 313	1.90	31-10934
LKT 20.0-480-DD60	20.00	21.50	3 x 76.7	24.0	39.8	3 x 0.7	85 x 313	1.90	31-10935
LKT 22.5-480-DD60	22.50	24.19	3 x 86.3	27.0	44.7	3 x 0.6	85 x 313	1.90	31-10936
LKT 23.4-480-DD60	23.40	25.15	3 x 89.8	28.1	46.4	3 x 0.6	85 x 313	1.90	31-10937
LKT 25.0-480-DD60	25.00	26.88	3 x 95.9	30.0	49.7	3 x 0.6	85 x 355	2.20	31-10938



# Product Selection & Technical Data

## DD60 Capacitors for 600 V / 60 Hz System Voltage

**FRAKO** type LKT -DD60 600V capacitors are multi-purpose capacitors for use in Power Factor and Harmonic Filter Systems.

Continuous voltage capability of 110% rated voltage makes them suitable for use with or without a series (tuning, de-tuning or filter) reactor.

Permitted operating & overvoltages	
<b>Max. Voltage</b> (continuous)	660 V
<b>8 hours / day</b>	726 V
<b>30 minutes / day</b>	759 V
<b>5 minutes</b>	792 V
<b>1 minute</b>	858 V

### Product Selection Chart

Catalogue No.	Power	Power	Capacitance	Current		ESR	Dimensions	Weight	Part No.
	$Q_C$	w/ 7%		$I_{Nom}$	$I_{Max}$				
	[kVAR]	[kVAR]	$C_N \Delta$	[A]	[A]	at 1 kHz	d x h	[kg]	
			[ $\mu$ F]			[m $\Omega$ ]	[mm]		

Rated Voltage: 600 V / 60 Hz

LKT 1.0-600-DD60	1.00	1.07	3 x 2.4	1.0	1.6	3 x 22.1	85 x 250	1.55	31-10939
LKT 1.5-600-DD60	1.50	1.61	3 x 3.7	1.5	2.4	3 x 14.3	85 x 250	1.55	31-10940
LKT 2.0-600-DD60	2.00	2.15	3 x 4.9	1.9	3.2	3 x 10.8	85 x 250	1.55	31-10941
LKT 2.5-600-DD60	2.50	2.68	3 x 6.1	2.4	4.0	3 x 8.7	85 x 250	1.55	31-10942
LKT 3.0-600-DD60	3.00	3.22	3 x 7.3	2.9	4.8	3 x 7.3	85 x 250	1.55	31-10943
LKT 4.0-600-DD60	4.00	4.30	3 x 9.7	3.8	6.4	3 x 5.5	85 x 250	1.55	31-10944
LKT 5.0-600-DD60	5.00	5.37	3 x 12.4	4.8	7.9	3 x 4.3	85 x 250	1.55	31-10945
LKT 6.0-600-DD60	6.00	6.45	3 x 14.8	5.8	9.5	3 x 3.6	85 x 250	1.55	31-10946
LKT 7.5-600-DD60	7.50	8.06	3 x 18.5	7.2	11.9	3 x 2.9	85 x 250	1.55	31-10947
LKT 10.0-600-DD60	10.00	10.75	3 x 24.6	9.6	15.9	3 x 2.2	85 x 250	1.55	31-10948
LKT 11.7-600-DD60	11.70	12.57	3 x 28.8	11.3	18.6	3 x 1.8	85 x 250	1.55	31-10949
LKT 12.5-600-DD60	12.50	13.44	3 x 30.7	12.0	19.8	3 x 1.7	85 x 250	1.55	31-10950
LKT 15.0-600-DD60	15.00	16.12	3 x 36.9	14.4	23.8	3 x 1.4	85 x 313	1.90	31-10951
LKT 16.7-600-DD60	16.70	17.95	3 x 41.0	16.1	26.6	3 x 1.3	85 x 313	1.90	31-10952
LKT 17.5-600-DD60	17.50	18.80	3 x 43.0	16.8	27.8	3 x 1.2	85 x 313	1.90	31-10953
LKT 20.0-600-DD60	20.00	21.5	3 x 49.1	19.2	31.7	3 x 1.1	85 x 313	1.90	31-10954
LKT 22.5-600-DD60	22.50	24.19	3 x 55.2	21.7	35.7	3 x 1.0	85 x 355	2.20	31-10955
LKT 23.4-600-DD60	23.40	25.15	3 x 57.4	22.5	37.2	3 x 0.9	85 x 355	2.20	31-10956
LKT 25.0-600-DD60	25.00	26.88	3 x 61.5	24.1	39.7	3 x 0.9	85 x 355	2.20	31-10957



# Product Selection & Technical Data

## DP60 Capacitors with 690 and 800 V / 60Hz rated Voltage

**FRAKO** type LKT -DP60 690V and 800V capacitors are multi-purpose capacitors for use in Power Factor and Harmonic Filter Systems.

These are typically used in 600V class applications where the voltage or current are abnormally high or where high impedance reactors are used in series with capacitors.

Permitted operating-& overvoltages	
<b>Rated Voltage</b>	690 V / 800 V
<b>8 hours / day</b>	759 V / 880 V
<b>30 minutes / day</b>	794 V / 920 V
<b>5 minutes</b>	828 V / 960 V
<b>1 minute</b>	897 V / 1040 V

### Product Selection Chart

Catalogue No.	Power	Power	Capacitance	Current		ESR at 1 kHz	Dimensions d x h	Weight	Part No.
	$Q_C$ [kVAR]	$Q_C$ 600 V [kVAR]		$C_N \Delta$ [μF]	$I_{Nom}$ [A]				

**Rated Voltage: 690 V / 60 Hz**

<b>LKT 12.5-690-DP60</b>	12.50	9.50	3 x 23.2	10.5	15.7	3 x 2.3	85 x 250	1.55	31-10958
<b>LKT 15.0-690-DP60</b>	15.00	11.30	3 x 27.9	12.6	18.8	3 x 1.9	85 x 250	1.55	31-10959
<b>LKT 20.0-690-DP60</b>	20.00	15.10	3 x 37.1	16.7	25.1	3 x 1.4	85 x 250	1.55	31-10960
<b>LKT 22.1-690-DP60</b>	22.10	16.70	3 x 41.0	18.5	27.7	3 x 1.3	85 x 313	1.90	31-10961
<b>LKT 25.0-690-DP60</b>	25.00	18.90	3 x 46.4	20.9	31.4	3 x 1.1	85 x 313	1.90	31-10962
<b>LKT 30.0-690-DP60</b>	30.00	22.70	3 x 55.7	25.1	37.7	3 x 1.0	85 x 355	2.20	31-10963

**Rated Voltage: 800 V / 60 Hz**

<b>LKT 8.0-800-DP60</b>	8.00	4.50	3 x 11.0	5.8	8.7	3 x 4.8	85 x 250	1.55	31-10964
<b>LKT 12.6-800-DP60</b>	12.60	7.10	3 x 17.4	9.1	13.7	3 x 3.0	85 x 250	1.55	31-10965
<b>LKT 16.0-800-DP60</b>	16.00	9.00	3 x 22.1	11.5	17.3	3 x 2.4	85 x 250	1.55	31-10966
<b>LKT 25.2-800-DP60</b>	25.20	14.20	3 x 34.8	18.6	27.3	3 x 1.5	85 x 313	1.90	31-10967

# Technical Data

## Dimensional Data

As a convenience for panel builders and assembly, all type DD60 and DP60 capacitors are produced with a common diameter of 85 mm (3.35"). Depending on the kVAR rating, the height of the capacitors varies from 198 mm (7.79") to 355 mm (13.97").

## Capacitor Weight

**FRAKO** capacitors vary in weight depending on their height. There are four different heights and four corresponding weights.

Height excluding terminal	Height including terminal	Weight including terminal
163 mm (6.42")	198 mm (7.79")	1.20 kg (2.65 lbs)
215 mm (8.46")	250 mm (9.84")	1.55 kg (3.42 lbs)
278 mm (10.94")	313 mm (12.32")	1.90 kg (4.19 lbs)
320 mm (12.6")	355 mm (13.97")	2.20 kg (4.85 lbs)

## Applying capacitors to other voltages or frequencies

When applying capacitors at a lower voltage, the kVAR rating reduces. Use the factors in the table below to calculate the kVAR rating for your capacitor when used in lower system voltage.

System Voltage	Capacitor Voltage				
	240 V	480 V	600 V	690 V	800 V
208 V	0.75	0.19	0.12	0.09	0.07
240 V	1.00	0.25	0.16	0.12	0.09
380 V	-	0.63	0.40	0.30	0.23
480 V	-	1.00	0.64	0.48	0.36
600 V	-	-	1.00	0.76	0.56

When a 60 Hz rated capacitor will be operated in a 50 Hz network, the kVAR rating is reduced. Apply the factor of 0.83 to the capacitor 60 Hz kVAR rating to determine the 50 Hz kVAR rating.

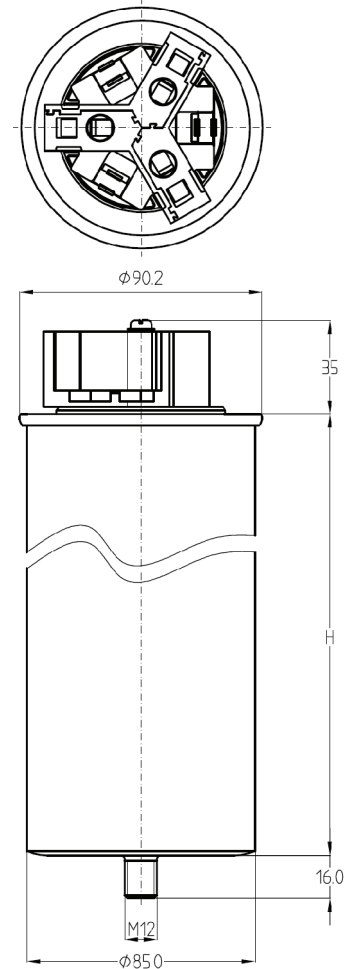

*Voltage example:*

*Operating a 25 kVAR, 480V (60Hz) capacitor in a 380V (60Hz) system:*

$$25 \text{ kVAR} \times 0.63 = 15.8 \text{ kVAR}$$

*Frequency example:*

*Operating a 25 kVAR, 60 Hz capacitor in a 50 Hz system:*

$$25 \text{ kVAR} \times 0.83 = 20.8 \text{ kVAR}$$

# Capacitor Calculations

Capacitance C	[F]	$C = \frac{kVAR \times 1000}{V_{LL}^2 \times 2\pi f}$
Capacitor Power $Q_C$	[kVAR]	$kVAR = Q_C = \frac{2\pi f \times C \times V_{LL}^2}{1000}$
Capacitor Power $Q_C$ when operated with harmonic filter reactor	[kVAR]	$kVAR = Q_C = \left( \frac{2\pi f \times C \times V_{LL}^2}{1 - p} \right) \div 1000$
Capacitor Power $Q_C$ when operated in lower system voltage	[kVAR]	$kVAR_{System} = kVAR_{Capacitor} \times \left( \frac{V_{System}}{V_{Capacitor}} \right)^2$
Capacitor Power $Q_C$ when operated in a 50 Hz network	[kVAR]	$kVAR_{50Hz} = kVAR_{60Hz} \times \left( \frac{50 \text{ Hz}}{60 \text{ Hz}} \right)$
Capacitor Current I	[A]	$Amps = I = \frac{kVAR \times 1000}{V_{LL} \times \sqrt{3}}$
Voltage Boost with capacitors operated	[%]	$Voltage \ boost = \frac{Q_C \times Z_{XFMR}}{S_{XFMR}}$
Capacitive Reactance $X_C$	[Ohms]	$X_C = \frac{1}{2\pi f \times C}$
Resonance Frequency $f_r$	[Hz]	$f_r = f \times \sqrt{\frac{S_{SC}}{Q_C}}$

## Key Symbols

$V_{LL}$  = Voltage (Line-Line) [V]

I = Current [A]

f = Network Frequency [Hz]

$f_r$  = Resonance Frequency [Hz]

C = Capacitor Capacitance [F]

$Q_C$  = Capacitor Power [kVAR]

p = Detuning Factor [%]

$Z_{XFMR}$  = Transformer Short Circuit Power [%]

$S_{XFMR}$  = Transformer Power [kVA]

$S_{SC}$  = Short Circuit Power network [MVA]

# Leading-edge technology for safe and reliable network solutions since 1928



## Capacitor Duty Contactors

- Patented design for capacitors
- Pre-insertion resistors
- Suppresses voltage transients during switching
- Dampens capacitor inrush current
- Rated life >100,000 operations
- Can extend capacitor life
- For 600V or less

## Modular Capacitor Assemblies

- Pre-engineered auto-switching capacitor assemblies
- Capacitors, contactors, busbar system and fuses. Filter reactors are optional.
- One or two stages up to 100 kVAR
- 240 V, 480 V and 600 V
- Fast and easy assembly of large automatic PFC systems

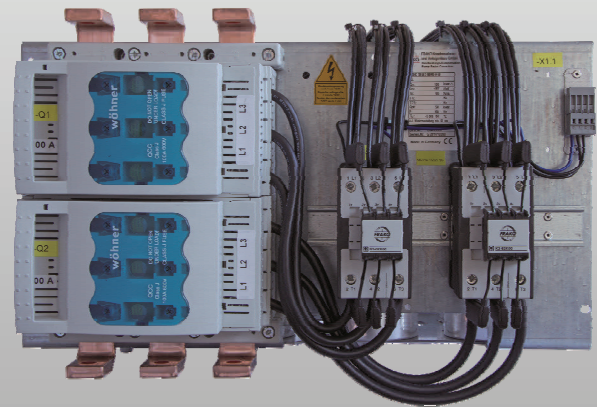

11/2015 © FRAKO GmbH - Subject to technical changes

### FRAKO North America Office:

Allied Industrial Marketing, Inc.  
W62 N248 Washington Avenue, Suite #208  
Cedarburg, WI 53012

Phone: 1-262-618-2403 (GMT -6)  
Homepage: [www.alliedindustrialmarketing.com](http://www.alliedindustrialmarketing.com)  
Email: [info@alliedindustrialmarketing.com](mailto:info@alliedindustrialmarketing.com)